

NEUNUTZUNG
PARZELLE NR. 1132
8570 WEINFELDEN

ebnetepartner ag

**UNTERGESCHOSS
SITUATION**

MST. 1:100/500

Ebnetepartner AG | Amriswilerstrasse 57 | CH-8570 Weinfelden | phone +41 (0)71-626 20 60 | fax +41 (0)71-626 20 61 | info@ebnetepartner.ch | www.ebnetepartner.ch

ebnetepartner ch

| 01 | Gez. be | form. 84/60 | dat. 28.09.09 | rev.

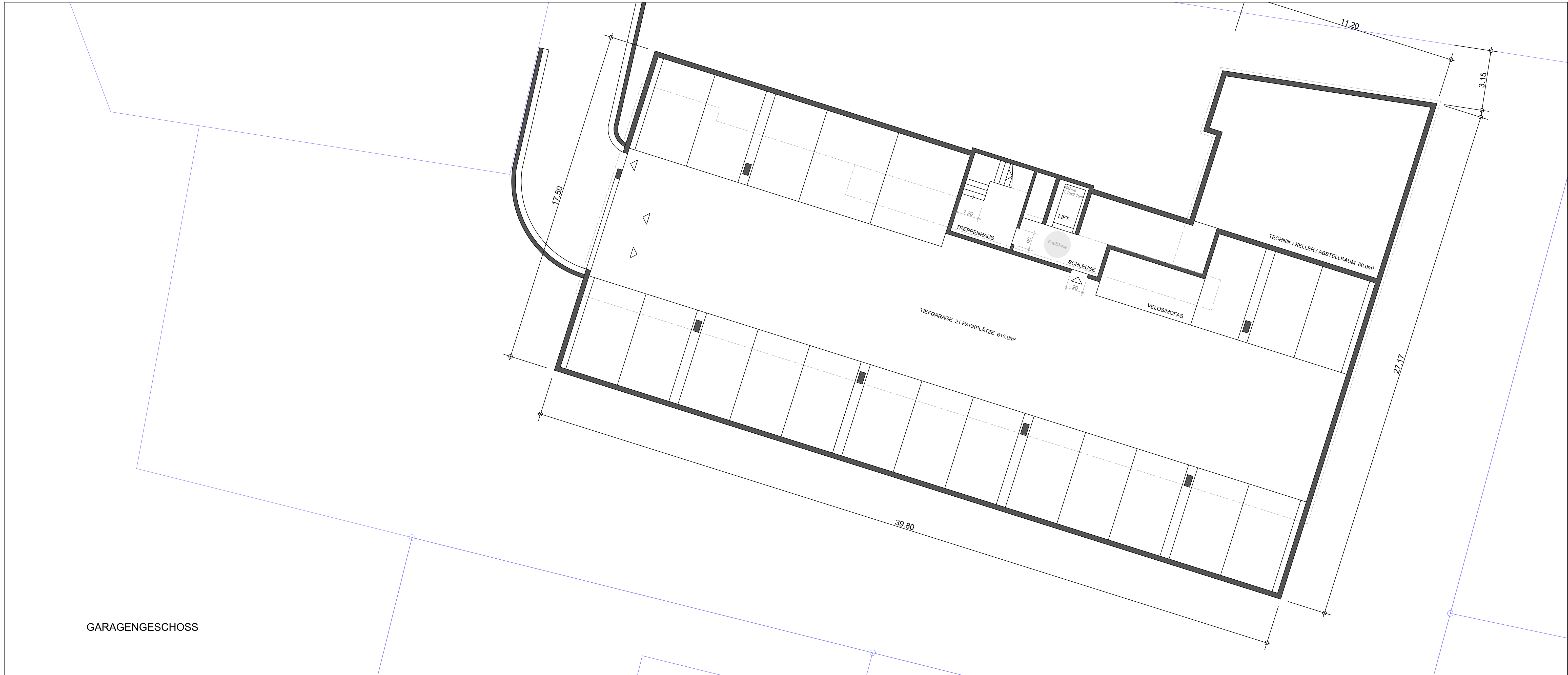
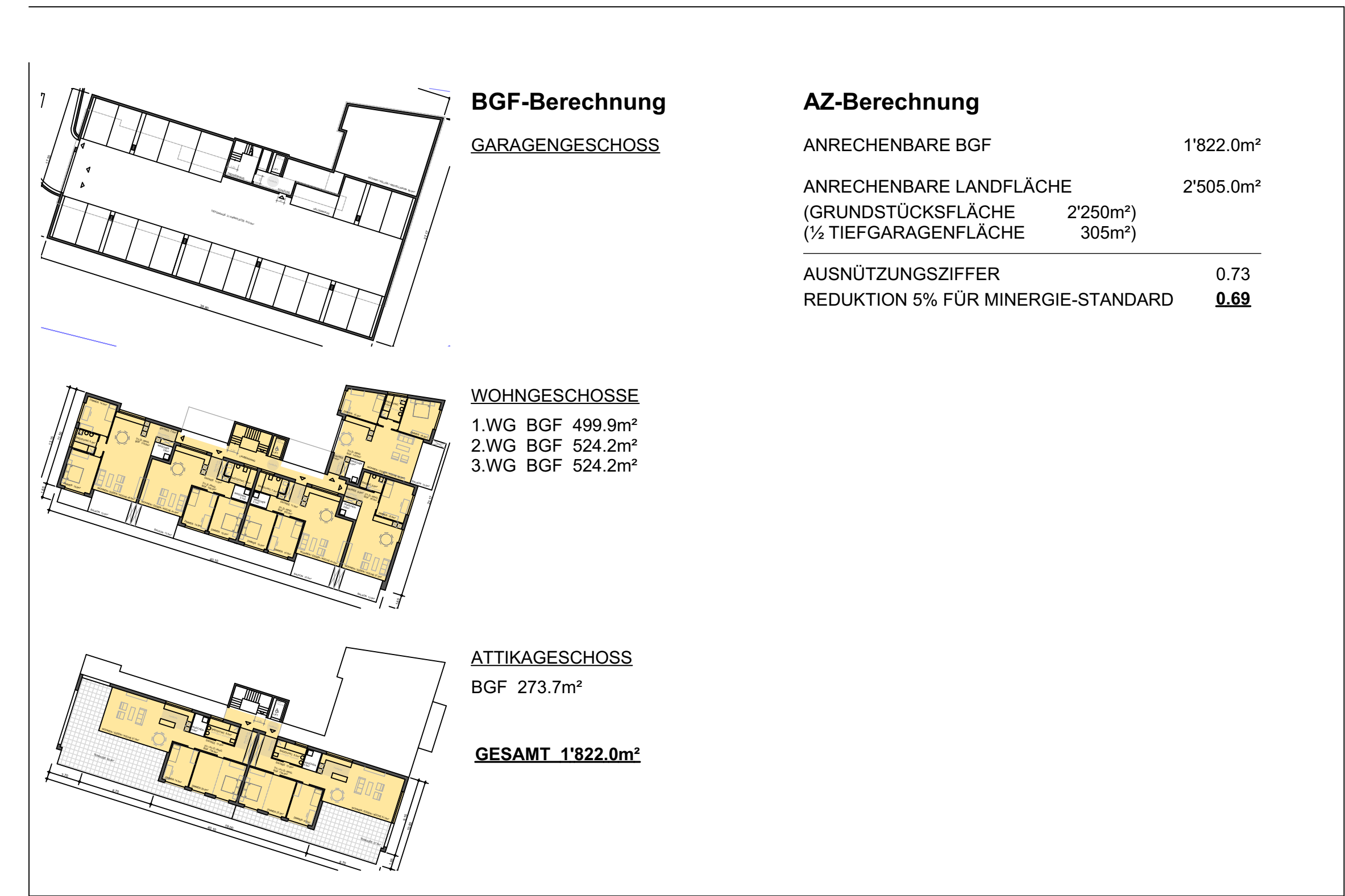
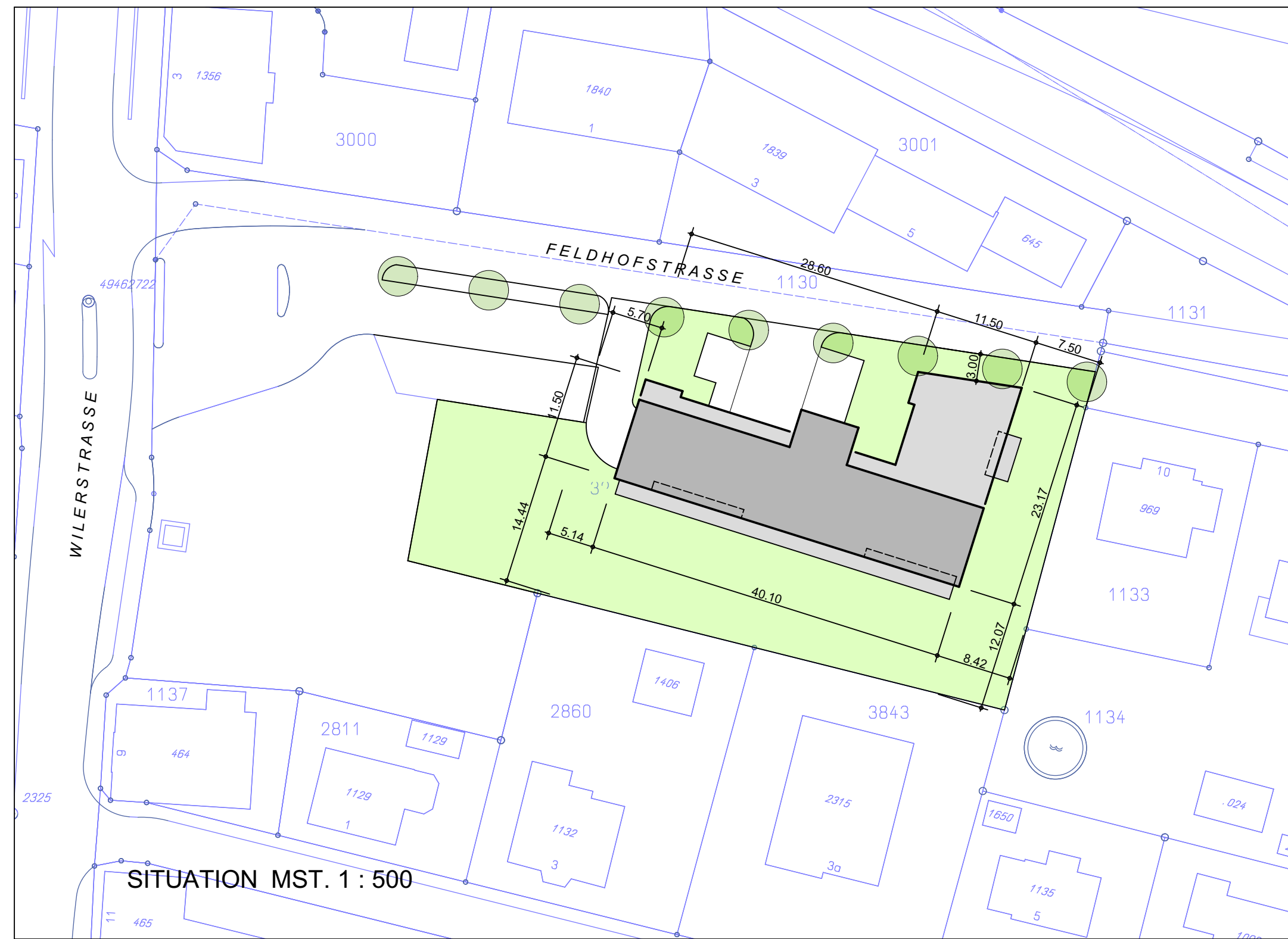
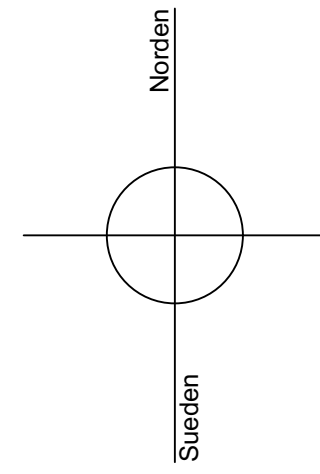

NEUNUTZUNG
PARZELLE NR. 1132
8570 WEINFELDEN

ebneterp^{artner}ag

**FASSADEN
SCHNITT**

MST. 1:100

Ebnetar Partner AG | Amriswilerstrasse 57 | CH-8570 Weinfelden |
phone +41 (0)71-626 20 60 | fax +41 (0)71-626 20 61 | info@ebnetar.ch | www.ebnetar.ch

ebnetar^{ch}

| 04 | Gez. be | form. 84/60 | dat. 28.09.09 | rev.

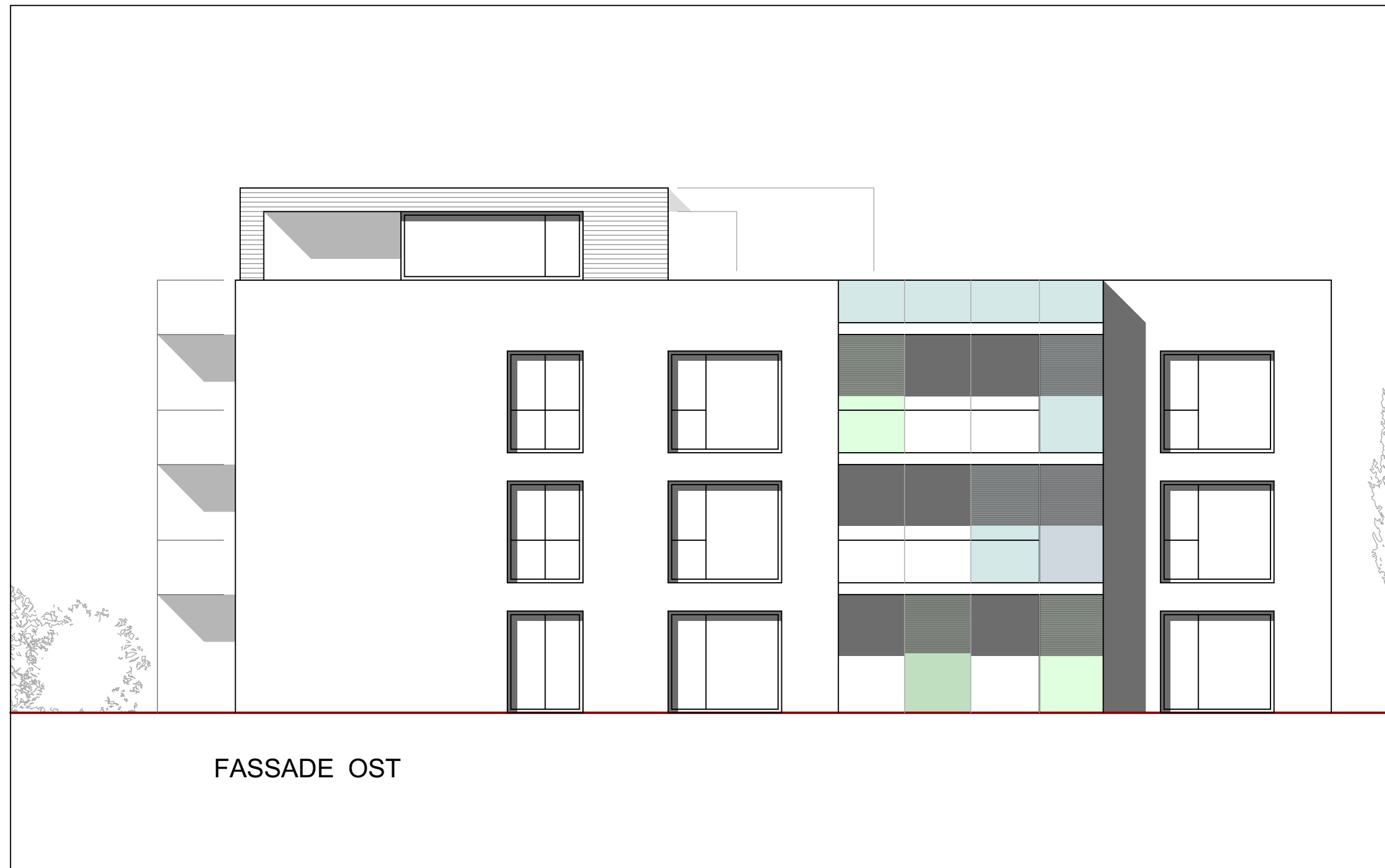
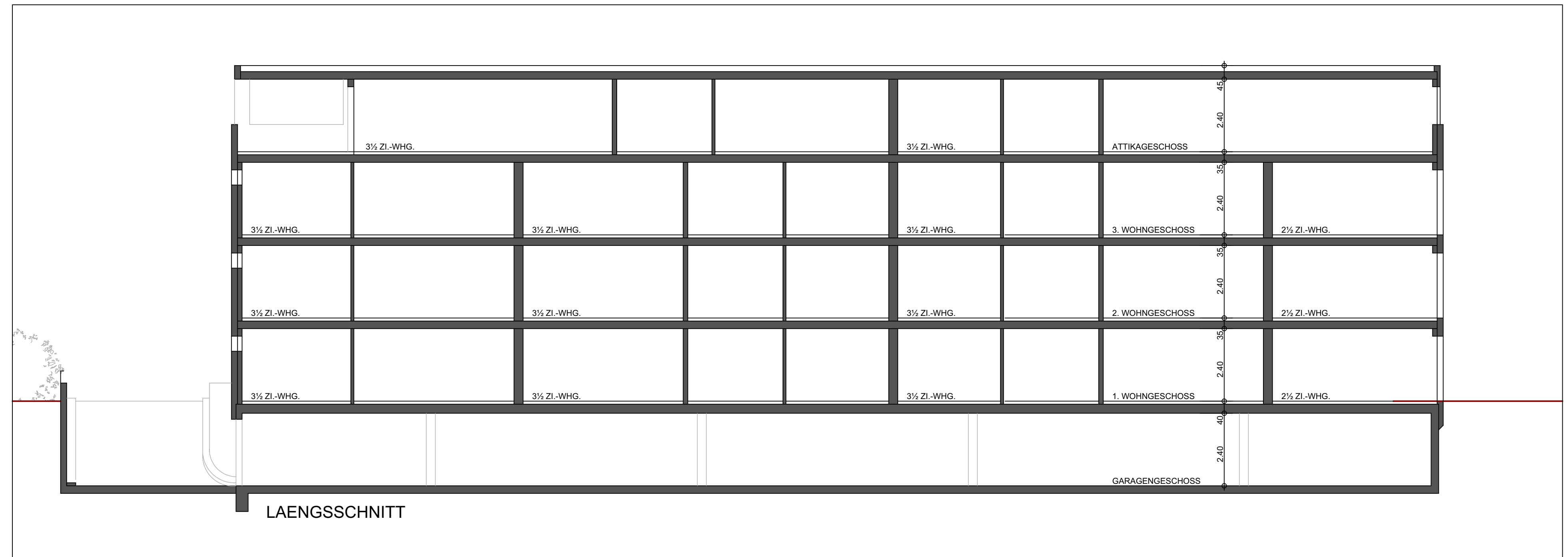

1. WOHNGESCHOSS
UMGEBUNG

MST. 1:100



1. WOHNGESCHOSS / UMGEBUNG

GRUNDRISSE
SCHNITT

MST. 1:100

